

SELECTION/DIMENSIONS

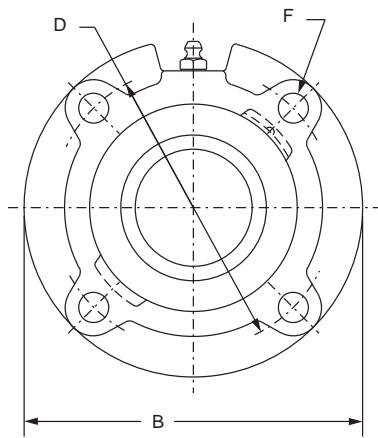

Setscrew Ball Bearings SCM MEDIUM DUTY PILOTED FLANGE BEARINGS



Lube Fitting Thread Size:
1/8-27 NPT

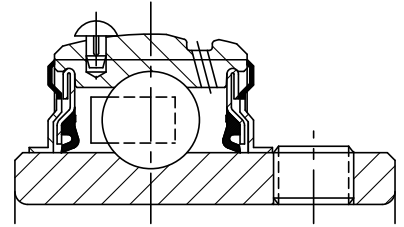
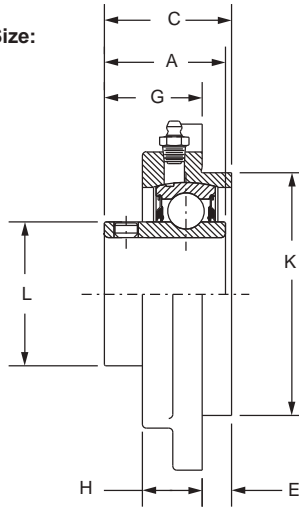

Series	Shaft Size	Part No.	Description
206	1	126167	FC-SCM-100
	25mm	125940	FC-SCM-25M
207	1-3/16	126168	FC-SCM-103
	1-1/4	124224	FC-SC-104
	30mm	125941	FC-SCM-30M
208	1-7/16	126170	FC-SCM-107
	1-1/2	126171	FC-SCM-108
	35mm	125942	FC-SCM-35M
209	1-1/2	056492	FC-SCM-108L
	1-5/8	065644	FC-SC-110L
	40mm	125943	FC-SCM-40M
210	1-11/16	126172	FC-SCM-111
	1-3/4	126173	FC-SCM-112
	45mm	125944	FC-SCM-45M
211	1-15/16	126174	FC-SCM-115
	2	126175	FC-SCM-200
	50mm	125945	FC-SCM-50M
212	2-3/16	126176	FC-SCM-203
	2-1/4	126177	FC-SCM-204
	55mm	125946	FC-SCM-55M
214	2-7/16	126178	FC-SCM-207
	2-1/2	126179	FC-SCM-208
	65mm	125947	FC-SCM-65M
216	2-15/16	126180	FC-SCM-215
	3	126182	FC-SCM-300
	75mm	125948	FC-SCM-75M
218	3-7/16	126183	FC-SCM-307
	3-1/2	126184	FC-SCM-308
	85mm	125949	FC-SCM-85M

© Assembled to order

FEATURES/BENEFITS PAGE B4-3	HOW TO ORDER/NOMENCLATURE PAGE B4-5	SELECTION PAGE B4-6	ACCESSORIES PAGE B4-98
--------------------------------	--	------------------------	---------------------------

SELECTION/DIMENSIONS



Setscrew Ball Bearings SCM MEDIUM DUTY PILOTED FLANGE BEARINGS

Bearing Reference Guide

ULTRA KLEEN

E-Z KLEEN

Extreme Duty

Setscrew Ball Bearing

GRIP TIGHT

D-LOK Ball Bearing

Series	Shaft Size	Weight lbs. kgs.	A	B	C	D	E	F Bolt Dia.	G	H	K	L
206	1	3.3	1.52	4.38	1.53	3.63	0.25	3/8	1.28	0.81	3.000/2.998	1.57
	25mm	1.4	38.6	111.3	38.9	92.2	6.4	M10	32.5	20.6	76.20/76.15	39.9
207	1-3/16	4.2	1.71	5.00	1.78	4.13	0.38	3/8	1.40	0.84	3.375/3.373	1.84
	1-1/4	4.2										
	30mm	1.9	43.4	127.0	45.2	104.9	9.7	M10	35.6	21.3	85.73/85.67	46.7
208	1-7/16	4.8	1.94	5.25	1.98	4.38	0.44	7/16	1.54	0.89	3.625/3.623	2.05
	1-1/2	4.6										
	35mm	2.1	49.3	133.4	50.3	111.3	11.2	M12	39.1	22.6	92.08/92.02	52.1
209	1-1/2	5.6	1.94	5.75	1.95	4.75	0.44	1/2	1.51	0.91	4.000/3.998	2.22
	1-5/8	5.6										
	40mm	2.5	49.3	146.1	49.5	120.7	11.2	M12	38.4	23.1	101.60/101.55	56.4
210	1-11/16	6.4	1.94	6.13	1.98	5.13	0.47	1/2	1.51	0.92	4.250/4.248	2.43
	1-3/4	6.3										
	45mm	2.9	49.3	155.7	50.3	130.3	11.9	M12	38.4	23.4	107.95/107.90	61.7
211	1-15/16	7.6	2.22	6.38	2.35	5.38	0.63	1/2	1.72	1.00	4.500/4.498	2.71
	2	7.4										
	50mm	3.4	56.4	162.1	59.7	136.7	16.0	M12	43.7	25.4	114.30/114.25	68.8
212	2-3/16	9.5	2.31	7.13	2.54	6.00	0.88	1/2	1.67	1.00	5.000/4.998	2.97
	2-1/4	9.8										
	55mm	4.4	58.7	181.1	64.5	152.4	22.4	M12	42.4	25.4	127.00/126.95	75.4
214	2-7/16	13.2	2.54	7.63	2.80	6.50	1.13	1/2	1.67	1.06	5.500/5.498	3.31
	2-1/2	13.0										
	65mm	5.9	64.5	193.8	71.1	165.1	28.7	M12	42.4	26.9	139.70/139.65	84.1
216	2-15/16	18.8	2.38	8.75	3.02	7.50	1.25	5/8	1.77	1.19	6.375/6.373	3.83
	3	18.6										
	75mm	8.5	60.5	222.3	76.7	190.5	31.8	M16	45.0	30.2	161.93/161.87	97.3
218	3-7/16	28.7	2.56	10.25	3.33	8.63	1.13	3/4	2.21	1.63	7.375/7.373	4.35
	3-1/2	28.5										
	85mm	13.5	65.0	260.4	84.6	219.1	28.6	M18	56.1	41.4	187.33/187.27	110.5

FEATURES/BENEFITS PAGE B4-3	HOW TO ORDER/NOMENCLATURE PAGE B4-5	SELECTION PAGE B4-6	ACCESSORIES PAGE B4-98
--------------------------------	--	------------------------	---------------------------